

"Math Is Cool" Championships — 2020-21

7/8th Grade — February 10, 2021

Sponsored by: Columbia Basin College

GENERAL INSTRUCTIONS applying to all tests:

- *Good sportsmanship is expected throughout the competition by all involved (competitors and observers). Display of poor sportsmanship will result in disqualification.*
- *Competitors may not use calculators or any other aids on any portion of this contest.*
- *Unless stated otherwise:*
 - *Express all rational, non-integer answers as common fractions, except in problems dealing with money, where you should give the answer as a decimal rounded to the nearest cent.*
 - *For 5th grade and up, all fractions and ratios must be reduced to simplest form, all radicals must be simplified, and all denominators must be rationalized.*
 - *Do not round or approximate answers. Leave answers in terms of π or other irrational quantities (e.g., $\sqrt{2}$), where applicable.*
- *Units are not necessary as part of your answer, unless it is a problem that deals with time, in which case, AM or PM is required. However, if you choose to use units, they must be correct.*
- *Record all answers on the colored cover sheets in the answer column only.*
- ***Be sure that the student name, school, team number, etc. has been filled out at the top of each answer sheet.***
- *Tests will be scored as a 0 if answers are not recorded correctly on the answer sheets.*
- *Blank answer sheets and answer sheets with no name will be scored as a 0.*

FINAL SCORES AND AWARDS

Individual awards are determined by both the Mental Math and Individual Test scores. Individual ties are broken based on the following, in this order: total scaled individual points, total number of correct answers on the Individual Test, Mental Math raw score, number of correct answers from Individual Test #31-40, number of correct answers from Individual Test #16-30, highest numbered question answered correctly on the Individual Test working backwards from #40.

Team (School) awards are based on the highest score from amongst each of the school's "teams of 4 students" in each event and is calculated as $2 \cdot (\text{Sum of highest 3 Mental Math scores}) + 2 \cdot (\text{Multiple Choice}) + 6 \cdot (\text{Team}) + 3 \cdot (\text{Relay}) + 1 \cdot (\text{College Bowl})$, for approximate weights of 25%, 20%, 30%, 15% and 10% respectively. Team ties are broken based on highest event score in order of the events, starting with Mental Math.

MENTAL MATH TEST - 30 sec./quest., 8 problems, ~8%/25% of individ./team scores

The proctor will read each question twice. You may not do any writing or talking while arriving at a solution. Record only your answer on your answer sheet. You may not change, cross out, erase, or write over an answer once you have written it down. The maximum wait time is 30 seconds after completion of the second reading of the question. Correct answers receive 1 point.

INDIVIDUAL TEST - 35 minutes, 40 problems, ~92% of individual score

When you are prompted to begin, tear off the colored answer sheet and begin testing. No talking during this individual test. You will be given a 5 minute time warning. Correct answers receive 2 points for problems 1-30 and 3 points for 31-40 (in the scaled score).

"Math Is Cool" Championships — 2020-21

7/8th Grade — February 10, 2021

Sponsored by: Columbia Basin College

Final Score (out of 8)

Room # School Name Student Name Team #

Mental Math - ~25% of team score & ~8% of individual score

Error! Reference source not found.

STUDENT: DO NOT WRITE IN SHADED REGIONS (or anywhere else, other than the answer box)

Answer		Scorer 2	Scorer 1
		0 or 1	0 or 1
1			
2			
3			
4			
5			
6			
7			
8			
7/8th Grade		TOTAL:	

"Math Is Cool" Championships — 2020-21

7/8th Grade — February 10, 2021

Sponsored by: Columbia Basin College

Key

Mental Math Contest - Answer Key

30 seconds per question - ~25% of team score & ~8% of individual score

SCORERS — Write-overs, Cross-outs, and Erasures Must be Marked Incorrect (0)
Bracketed items [...] in the answer key are optional.

7/8th Grade

Answer		
1	113	What is seventy-seven plus thirty-six?
2	32	A composite number is a number with at least one factor in addition to one and the number itself. What is the smallest composite number greater than thirty?
3	45 [mph]	A train travels at an average speed of thirty miles per hour. A car travels at an average speed that is one and a half times as fast as the train. How many miles per hour is the car's average speed?
4	37	When rolling two standard dice the probability of rolling two ones as a reduced common fraction is $\frac{A}{B}$. What is the value of $A + B$?
5	2 [inches]	A rectangle is four inches wide and fifteen inches long. What is the number of inches in the radius of the largest circle that can completely fit inside the rectangle without going outside the rectangle?
6	144	What is one hundred multiplied by one point two and then multiplied by one point two again?
7	5	Abe, Ben, Cara, and Dina are randomly arranged in a line. The probability that Dina stands at the front of the line as a reduced common fraction is $\frac{A}{B}$. What is the value of $A + B$?
8	5 [rectangles]	How many distinct rectangles with whole number side lengths are possible if the perimeter is twenty inches and a one by nine rectangle counts as the same as a nine by one rectangle?

"Math Is Cool" Championships — 2020-21

7/8th Grade — February 10, 2021

Sponsored by: Columbia Basin College

Individual Contest

Record all answers on the colored cover sheet. 35 minutes, 40 problems, ~92% of individual score.

No talking during this individual test. A 5-minute time warning will be given.

	Questions 1-30: 2 points each
1	What is $80 + 90 - 70$?
2	The probability that a number chosen randomly from the set $\{1, 2, 3, 4, 5, 6, 7\}$ is odd as a reduced common fraction is A/B . What is the value of $A + B$?
3	What is the number of degrees in a right angle?
4	How many nickels are equal in value to 2 dollars?
5	What is the product of 60 and 9?
6	Rashida has read 30 pages of <i>The Full Cupboard of Life</i> , from the Number One Ladies Detective Agency book series, which is 15 percent of the number of pages in the book. How many pages are in <i>The Full Cupboard of Life</i> ?
7	Olaf divides his favorite number by 8 and then adds 3. The result is 14. What is Olaf's favorite number?
8	How many vertices (corners) are there on a cube?
9	What is the square root of 144?
10	What is the remainder when 77 is divided by 12?
11	Solve the equation for x : $10x - 25 = 115$
12	A vine grows 6 inches per day. In how many days will the vine be 3 feet longer than it is now?
13	A jar contains 32 red marbles, 24 green marbles, and 8 blue marbles. The ratio of blue marbles to total marbles in the jar is A/B , as a reduced common fraction. What is the value of $A + B$?
14	A rectangle has a length of 17 inches and a width of 13 inches. What is the number of square inches in the area of the rectangle?
15	As a decimal, the mean (average) of the four smallest three-digit whole numbers is $A.B$, where A is a three-digit number and B is a single digit. What is the value of $A + B$?
16	One cantaloupe costs the same as five oranges. One orange costs the same as three bananas. How many bananas cost the same as two cantaloupes?

17	A car is driving at an average rate of 30 miles per hour. How many miles does the car travel in 10 minutes?
18	A set of numbers consists of the numbers shown: $\{2, 3, 4, 5, 6, 7, 8, 9, 10\}$ A new set of numbers is created by multiplying all the numbers in the first set by 4. What is the sum of all the numbers in the new set?
19	In a doubles tennis match there are two two-person teams. After a certain match, each player gives every other player in the match an elbow bump. How many total elbow bumps are exchanged?
20	Garfield writes the words representing the numbers 1 through 9 in alphabetical order. Then he replaces each word with the number it represents to form a 9-digit number. What is this 9-digit number?
21	The perimeter of a parallelogram is 200 inches, and the length of the longer side is three times the length of the shorter side. What is the number of inches in the length of the longer side?
22	On the lower half of a hill there are four paths to choose from. All four paths lead to the same spot half-way up the hill. From this spot to the top there are five paths to choose from. How many total routes are there to hike up the hill from bottom to top?
23	How many positive two-digit multiples of 7 are also multiples of 10?
24	A palindrome is a number that reads the same forwards as backwards, like 232. How many positive three-digit palindromes are there in which the three digits are not all the same?
25	There are 13 green skittles and 11 red skittles in a jar. Two skittles are taken from the jar at random without replacement. The probability as a reduced common fraction that both skittles are green is A/B . What is the value of $A + B$?
26	Let S_1 be the infinite arithmetic series whose first three terms are 10, 19, 28, . . . , let S_2 be the infinite geometric series whose first three terms are 5, 15, 45, . . . , and let S_3 be the sum of S_1 and S_2 . This means that the 1 st term of S_3 equals the sum of the 1 st terms of S_1 and S_2 , the 2 nd term of S_3 equals the sum of the 2 nd terms of S_1 and S_2 , and so on. What is the 6 th term in S_3 ?
27	Circle B has a radius that is four times the radius of Circle A. How many times larger is the area of Circle B than the area of Circle A?
28	The given system of equations has exactly one solution, (x, y) . For this solution what is $x + y$? $2x - 3y = 40$ $5x + 6y = 19$
29	In a survey of 600 households, exactly 17% of the households have at least one dog and at least one cat as pets, exactly 12% have at least one cat and no dogs as pets, and exactly 27% have at least one dog and no cats as pets. The remaining households have neither dogs nor cats as pets. The probability, as a reduced common fraction, that a household chosen at random from the 600 households has at least one dog as a pet is A/B . What is the value of $A + B$?

30	<p>Susan and Lisa are playing a series of tennis matches against each other. They use the board shown to keep track of wins and losses. The small oval around the 0 is moveable and when Susan wins a match, she moves it one number to the right. When Lisa wins a match, she moves it one number to the left. If Susan wins three matches and there have been no ties, how many total matches will they have played when the oval is moved to the left-hand 5 for the first time?</p>
	<div style="border: 1px solid black; display: inline-block; padding: 5px 20px;"> 5 4 3 2 1 0 1 2 3 4 5 </div>

Challenge Questions: 3 points each

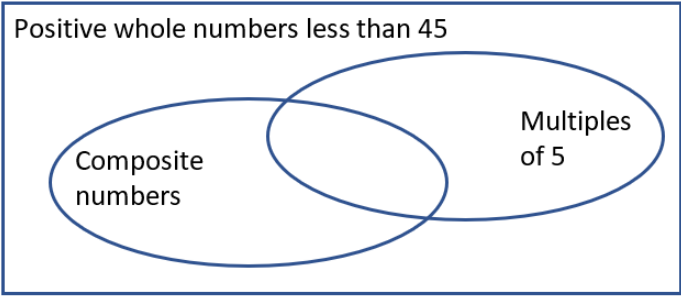
31	<p>Junior has one gallon of red paint and one gallon of blue paint. He takes one cup of red paint and adds it to the gallon of blue paint. After mixing it thoroughly, he takes out one cup of the mixed paint. Inside this cup, the ratio of paint that is blue is A/B, as a reduced common fraction. What is the value of $A + B$?</p>
32	<p>In the Venn diagram shown, how many positive whole numbers less than 45 are inside the rectangle but outside both ovals?</p> <div style="border: 1px solid black; padding: 10px; margin: 10px 0;"> <p style="margin: 0;">Positive whole numbers less than 45</p>  </div>
33	<p>A trapezoid has a height to area ratio of 1:18. The height of the trapezoid is less than 10 inches and both bases have integer lengths. What is the number of inches in the longest possible base of the trapezoid? Reminder: the bases of a trapezoid are the two parallel edges.</p>
34	<p>The base-9 number 567_9 equals the base-10 number N. The base-8 number A_8 also equals N. What is the value of A? (do not include the base-8 in your answer, just type A)</p>
35	<p>Bettina drives at an average rate of 40 miles per hour during the 4-mile drive from home to work in the morning. On the way back from work to home along the same route, she averages 24 miles per hour. What is her overall average rate in miles per hour for the two trips combined?</p>
36	<p>A certain infinite series of numbers is in the form $abcabcabc \dots$ where a, b, and c, each represent a distinct positive single digit number. For example, the series $\dots 123123123 \dots$ matches the given description, whereas $\dots 445445445 \dots$ does not. How many infinite series that match this description exist in which any three adjacent digits add up to more than 21? Note, the series $\dots 123123123 \dots$ and $\dots 231231231 \dots$ count as the same series, since they are infinite series and it therefore cannot be said what digit each series begins or ends with.</p>

37	An increasing arithmetic sequence begins with 10 as its first term, has 9 more terms, and the common difference is d . If $d = 2$, then the sum of the 10 terms is S . If $d = 10$, then the sum of the 10 terms is T . What is the value of $T - S$?
38	Consider the equation $0 = x^2 + kx - 24$. What is the sum of all possible values of k for which the equation has two integer solutions for x ?
39	A data set has six distinct positive integers. The median is 23 and the mean is less than the median. How many possible values of the largest integer in the set are there?
40	A local club plans to spend \$10,000 to cover the costs of hosting a baseball game. They expect to sell tickets that will generate a total of \$15,000 in income. If it rains on the day of the game, they won't sell any tickets and the club will lose all the money invested. The weather forecast for the day of game is a 20% probability of rain. On average and in dollars, how much profit can the club expect to earn?

"Math Is Cool" Championships - 2020-21

KEY

Individual Contest - Answer Key

SCORERS: Bracketed [...] items in answer key are optional. Just mark the score as 0 or 1 and add up those values to reflect total correct.
First Scorer - use the right-hand columns so 2nd scorer can do a blind scoring.

	Answer
1	100
2	[A + B =] 11
3	90 [degrees]
4	40 [nickels]
5	540
6	200 [pages]
7	88
8	8 [vertices]
9	12
10	5
11	[x =] 14
12	6 [days]
13	[A + B =] 9
14	221 [in ²]
15	[A + B =] 106

	Answer
16	30 [bananas]
17	5 [miles]
18	216
19	6 [elbow bumps]
20	854917632
21	75 [inches]
22	20 [routes]
23	1 [multiple]
24	81 [palindromes]
25	[A + B =] 59
26	1270
27	16 [times]
28	5
29	[A + B =] 36
30	11 [matches]

	Answer
31	[A + B =] 33
32	14 [numbers]
33	35 [inches]
34	[A =] 722 _[8]
35	30 [mph]
36	8 [series]
37	[T - S =] 360
38	0
39	38 [values]
40	[\$] 2000 [dollars]

7/8th Grade
February 10, 2021

"Math Is Cool" Championships - 2020-21

Total Correct (all columns)

Room #

SCHOOL NAME

STUDENT NAME

Team #

Individual Contest - Score Sheet

STUDENTS: DO NOT WRITE IN SHADED REGIONS

	Answer	1 or 0	1 or 0
1			
2			
3			
4			
5			
6			
7			
8			
9			
10			
11			
12			
13			
14			
15			
1-15 TOTAL:			

	Answer	1 or 0	1 or 0
16			
17			
18			
19			
20			
21			
22			
23			
24			
25			
26			
27			
28			
29			
30			
16-30 TOTAL:			

	Answer	1 or 0	1 or 0
31			
32			
33			
34			
35			
36			
37			
38			
39			
40			
31-40 TOTAL:			

7/8th Grade

February 10, 2021

Scorers: Just score as 0 or 1 and add up those values (i.e., just work with number correct).

"Math Is Cool" Championships — 2020-21

7/8th Grade — February 10, 2021

Sponsored by: Columbia Basin College

Team Multiple Choice Contest

	<p>USE THE FOLLOWING INFORMATION TO SOLVE PROBLEMS #1 THROUGH #4.</p> <p>The equation $y = 6x - 10$ has an infinite number of solutions in the form (x, y) where x stands for one number and y stands for the resulting number when the number that x represents is multiplied by 6 and then 10 is subtracted. For example $(2, 2)$ is a solution, because if x is replaced with two, the resulting value of y is $6(2) - 10$, which equals 2.</p>
1	<p>Which of the ordered pairs is also a solution to the equation?</p> <p>A) $(-1, 4)$ B) $(-1, -4)$ C) $(3, 8)$ D) $(3, 14)$ E) $(4, 16)$</p>
2	<p>When x equals 100, what does y equal?</p> <p>A) $50/3$ B) 30 C) 300 D) 590 E) 610</p>
3	<p>What is the value of x in the ordered pair $(x, 20)$?</p> <p>A) $1.\bar{6}$ B) 5 C) 15 D) 18 E) 110</p>
4	<p>How many solutions does the equation have in which both x and y are integers and $x + y$ equals an odd number between 0 and 30?</p> <p>A) 2 B) 4 C) 7 D) 11 E) 15</p>

Continued on Next Page

USE THE FOLLOWING BAR GRAPH TO SOLVE PROBLEMS #5 THROUGH #7.

Competitive Eating Records

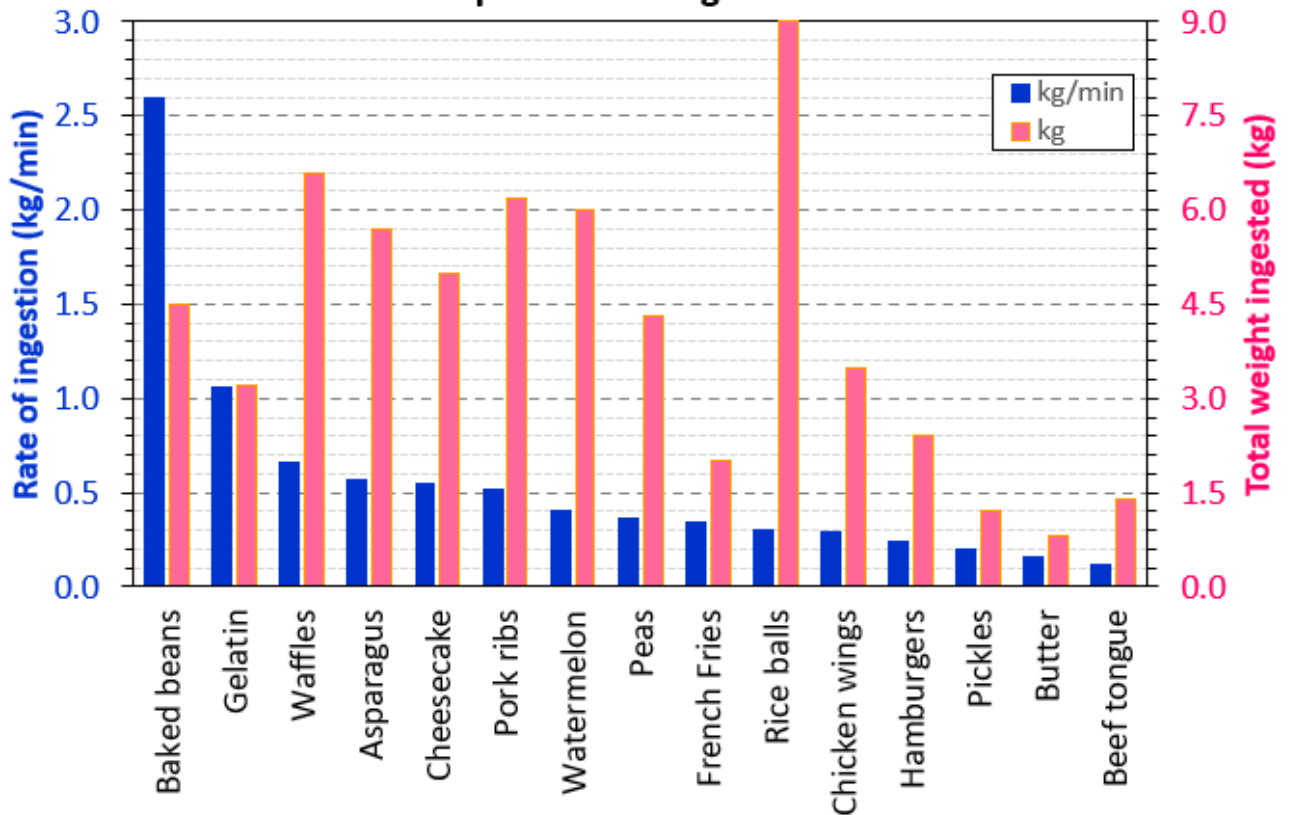

5 Which competitive eating record has the largest number of kilograms ingested?

- A) Baked Beans B) Rice Balls C) Waffles D) Gelatin E) Watermelon

6 Each food record in the table can be ranked based on how it compares to the other foods' rate of consumption and weight ingested. For example, we would rank Butter as 15th (last) for total weight ingested, and 14th for rate of ingestion. With rankings, the lower the number the better the ranking. In other words, a rank of 1 is better than a rank of 10.

What is the lowest sum when the rank of rate of ingestion is added to the rank of total weight ingested, for any of the 15 foods listed?

- A) 35 B) 18 C) 7 D) 6 E) 5

7 The ranks for rate of ingestion go from best to worst as you read from left to right on the bar graph. If the graph were to be redrawn so that the ranks for total weight ingested were to go from best to worst as you read left to right, how many records would not move from their current spot on the graph?

- A) 0 B) 1 C) 2 D) 4 E) 7

USE THE FOLLOWING INFORMATION TO SOLVE PROBLEMS #8 THROUGH #10.

Consider the segment shown with length 9 cm as Shape 0.



Imagine the middle three centimeters were removed and replaced with two 3-cm segments to form the new shape shown, which is Shape 1.



Then the process is repeated where all four of the segments have their middle third replaced by two segments of the same length to create Shape 2.

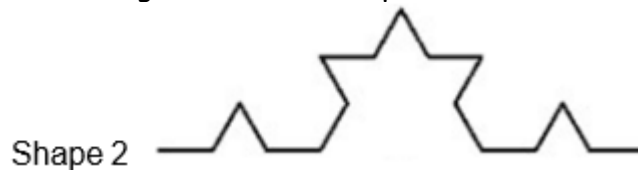

8 What is the sum of the lengths of the four segments in Shape 1?

- A) 9 cm B) 10 cm C) 12 cm D) 27 cm E) 36 cm

9 A figure made of three Shape 2s is shown here.



What is the sum of the lengths of all the segments in the perimeter of this figure?

- A) 36 cm B) 42 cm C) 45 cm D) 48 cm E) 54 cm

10 What is the length of the longest possible diagonal (shown here as \overline{AB}) that can be drawn in the figure from problem 9?

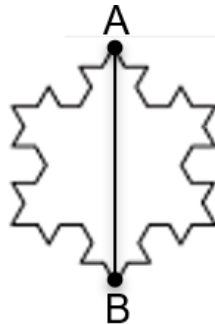

- A) $6\sqrt{3}$ cm B) 9 cm C) $8\sqrt{2}$ cm D) 12 cm E) Answer Not Given

"Math Is Cool" Championships — 2020-21

7/8th Grade — February 10, 2021

Key

Team Multiple Choice Contest - Answer Key

7/8th Grade

Correct responses are worth 2 points, incorrect responses are worth -1 point, and absence of a response is worth 0 points.

	Answer
1	C
2	D
3	B
4	A
5	B
6	E
7	B
8	C
9	D
10	A

"Math Is Cool" Championships — 2020-21

7/8th Grade — February 10, 2021

Final Score (out of 20)

Room #

School Name

Team #

Team Multiple Choice Contest - 15 minutes - ~20% of team score

Error! Reference source not found.

Correct responses are worth 2 points, incorrect responses are worth -1 point, and absence of a response is worth 0 points.

STUDENTS: DO NOT WRITE IN SHADED REGIONS

Answer		Scorer 2	Scorer 1
		-1, 0, or 2	-1, 0, or 2
1			
2			
3			
4			
5			
6			
7			
8			
9			
10			
7/8th Grade		TOTAL:	

"Math Is Cool" Championships — 2020-21

7/8th Grade — February 10, 2021

Sponsored by: Columbia Basin College

Team Contest

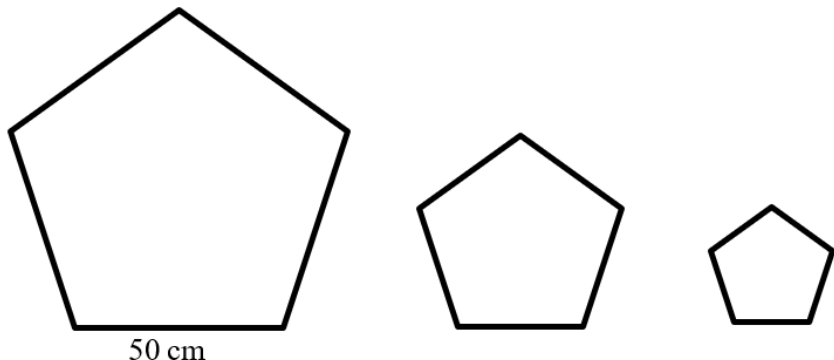
1	Evaluate the expression: $11(2 + 5) - 24$
2	All the socks in a drawer are mixed up and there is at least one pair of each color. If socks are pulled randomly from the drawer, the minimum number needed to be pulled in order to get at least one matching pair is 7 socks. How many different sock colors are in the drawer?
3	A chessboard is a square grid with 8 rows and 8 columns of small squares. When a game is set up pieces are placed on all squares in two rows on one side of the board and on all squares in two rows on the other side of the board. At the start of the game, what percent of the squares on the board have pieces on them?
4	While Romy is out walking, she takes three 90 degree right turns and ends up facing north. What direction was she facing before the three turns? Answer 1 for North, 2 for East, 3 for South, and 4 for West.
5	The product of $\frac{1}{3} \cdot \frac{3}{5} \cdot \frac{5}{7}$ as a reduced common fraction is A/B . What is the value of $A + B$?
6	Three of the angles in a certain quadrilateral are 100 degrees, 82 degrees, and 67 degrees. What is the number of degrees in the sum of the measures of the smallest two angles in the quadrilateral?
7	<p>In a regular polygon all sides have the same length. In the series of regular pentagons shown here, going left to right each successive pentagon has side lengths that are three-fifths the length of the sides of the previous pentagon. If the lengths of the sides on the largest pentagon are 50 cm, then what is the number of centimeters in the perimeter of the smallest pentagon?</p>  <p>50 cm</p>
8	A basketball team of 5 players has an average height of 74 inches. A new player joins the team who is 7 ft 2 in tall. By how many inches does the average height of the team increase when the new player joins?

Continued on next page.

- 9 A rectangular prism is 3 inches by 6 inches by 8 inches and has a cylindrical hole in it as shown. The diameter of the cylinder is 4 inches. The volume of this solid is $A - B\pi$ cubic inches, where A is a positive three-digit integer and B is a positive two-digit integer. What is the value of $A + B$?

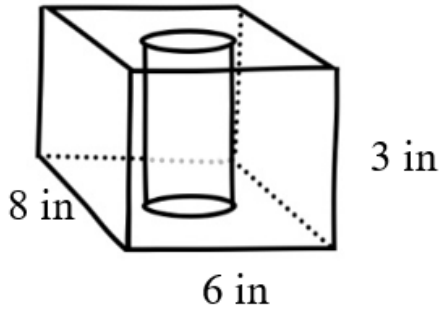

- 10 Aaron and Bonita are playing a game. Each chooses two numbers randomly from the list $\{1,2,3\}$ and multiplies them together. Individual numbers can be chosen multiple times. For example, it's possible for Aaron to choose two 1s and for Bonita to also choose two 1s. A person only wins if they have the bigger product. As a reduced common fraction, the probability that Bonita wins is A/B . What is the value of $A + B$?

"Math Is Cool" Championships — 2020-21

7/8th Grade — February 10, 2021

Key

Team Contest - Answer Key

7/8th Grade

Answer	
1	53
2	6 [colors]
3	50 [%]
4	2
5	[A + B =] 8
6	149 [degrees]
7	90 [cm]
8	2 [inches]
9	[A + B =] 156
10	[A + B =] 38

"Math Is Cool" Championships — 2020-21

7/8th Grade — February 10, 2021

Final Score (out of 10)

Room #

School Name

Team #

Team Contest - 15 minutes - ~30% of team score

Error! Reference source not found.

STUDENTS: DO NOT WRITE IN SHADED REGIONS

Answer		Scorer 2	Scorer 1
		0 or 1	0 or 1
1			
2			
3			
4			
5			
6			
7			
8			
9			
10			
7/8th Grade		TOTAL:	

"Math Is Cool" Championships — 2020-21

7/8th Grade — February 10, 2021

Sponsored by: Columbia Basin College

Linda Moore Triple Jump

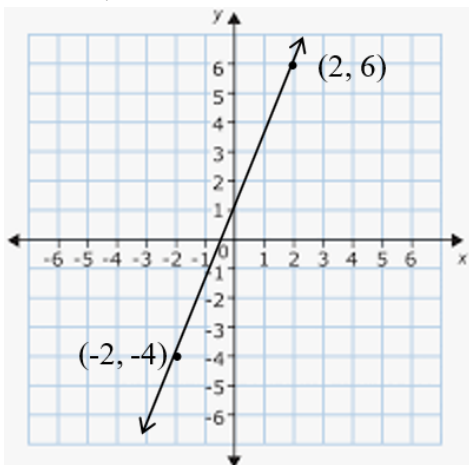
1	In the sentence, 'The quick brown fox jumps over the lazy dog', the ratio of e's to total letters as a reduced common fraction is A/B . What is the value of $A + B$?
2	If $x = 10$ and $y = -5$, then what is the value of the expression? $x^2 + 2xy + y^2$
3	Thomas the Tank Engine travels at an average rate of 10 miles per hour. How many minutes does it take him to travel 6 miles?
4	The currency system in the USA has \$1 bills, \$2 bills, \$5 bills, \$10 bills, \$20 bills, \$50 bills, and some other bills worth more than \$50. Malik has 5 bills in his wallet worth 51 dollars. What is the number of dollars in the value of the largest bill?
5	The slope of the line shown as a reduced common fraction is A/B . What is the value of $A + B$? 
6	In the expression $A/B + C/D$, each letter is replaced with a distinct digit from the set $\{3, 4, 6, 7\}$. The smallest possible value that can result from this process is the reduced common fraction E/F . What is the value of $E + F$?
7	A jar has a total of 7 beads in it. The beads are all either red or blue, and there is at least one of each color. How many different sets of 7 beads are possible that match this description? For example, one set would be 1 red and 6 blue.

Continued on next page.

8 In the figure shown, the radius of the circle is 9 cm. The perimeter of the inscribed equilateral triangle is $A\sqrt{B}$ cm. What is the value of $A + B$?

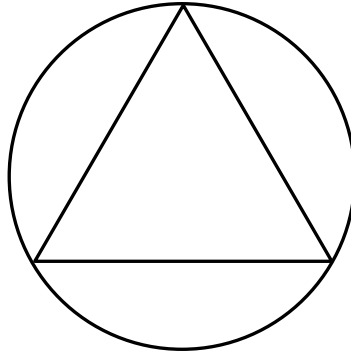

9 What is the largest positive three-digit whole number that has exactly six distinct perfect square factors?

10 How many rectangles of any size are in the drawing? Assume all angles are right angles.

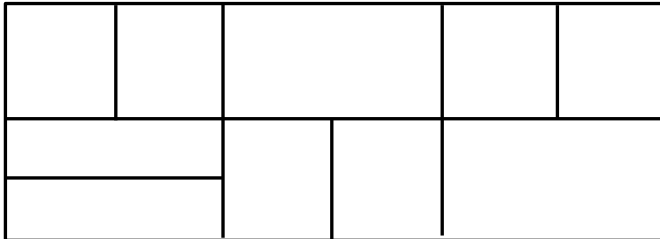

"Math Is Cool" Championships — 2020-21

7/8th Grade — February 10, 2021

Key

Linda Moore Triple Jump - Answer Key

7/8th Grade

	Answer
1	[A + B =] 38
2	25
3	36 [minutes]
4	[\$] 20 [dollars]
5	[A + B =] 7
6	[E + F =] 29
7	6 [mixtures]
8	[A + B =] 30
9	972
10	34 [rectangles]

"Math Is Cool" Championships — 2020-21

7/8th Grade — February 10, 2021

Final Score (out of 10)

Room #

School Name

Team #

Linda Moore Triple Jump - 15 minutes - ~30% of team score

Error! Reference source not found. [Need to revise this?](#)

STUDENTS: DO NOT WRITE IN SHADED REGIONS

Answer		Scorer 2	Scorer 1
		0 or 1	0 or 1
1			
2			
3			
4			
5			
6			
7			
8			
9			
10			
7/8th Grade		TOTAL:	

"Math Is Cool" Championships — 2020-21

7/8th Grade — February 10, 2021

Room #

School Name

Team #

Total Score for Each Round

College Bowl #1 (10 Possible)	College Bowl #2 (10 Possible)	College Bowl #3 (10 Possible)

DO NOT USE TALLY MARKS ON THIS SHEET. WRITE THE TOTAL SCORE FOR EACH ROUND.

"Math Is Cool" Championships — 2020-21
7/8th Grade — February 10, 2021

Room #

School Name

Team #

Total Score for Each Round

College Bowl #1 (10 Possible)	College Bowl #2 (10 Possible)	College Bowl #3 (10 Possible)

DO NOT USE TALLY MARKS ON THIS SHEET. WRITE THE TOTAL SCORE FOR EACH ROUND.

"Math Is Cool" Championships — 2020-21

7/8th Grade — February 10, 2021

Sponsored by: Columbia Basin College

Proctor
Copy

Mental Math Contest

MENTAL MATH - 30 seconds per question - ~25% of team score & ~8% of individual score

Error! Reference source not found.

1	What is seventy-seven plus thirty-six?	113
2	A composite number is a number with at least one factor in addition to one and the number itself. What is the smallest composite number greater than thirty?	32
3	A train travels at an average speed of thirty miles per hour. A car travels at an average speed that is one and a half times as fast as the train. How many miles per hour is the car's average speed?	45 [mph]
4	When rolling two standard dice the probability of rolling two ones as a reduced common fraction is $\frac{A}{B}$. What is the value of $A + B$?	37
5	A rectangle is four inches wide and fifteen inches long. What is the number of inches in the radius of the largest circle that can completely fit inside the rectangle without going outside the rectangle?	2 [inches]
6	What is one hundred multiplied by one point two and then multiplied by one point two again?	144
7	Abe, Ben, Cara, and Dina are randomly arranged in a line. The probability that Dina stands at the front of the line as a reduced common fraction is $\frac{A}{B}$. What is the value of $A + B$?	5
8	How many distinct rectangles with whole number side lengths are possible if the perimeter is twenty inches and a one by nine rectangle counts as the same as a nine by one rectangle?	5 [rectangles]

"Math Is Cool" Championships — 2020-21

7/8th Grade — February 10, 2021

Sponsored by: Columbia Basin College

Key

COLLEGE BOWL ROUND #1

#	Problem	Answer
1	Selina plays soccer three days a week for two hours each day. How many weeks will it take her to play twenty-four hours of soccer?	4 [weeks]
2	What is the product of twenty-four, one sixth, and eleven?	44
3	Jack Frost can freeze three bad guys in two minutes. Elsa can freeze seven bad guys in three minutes. Working together, how many bad guys could they freeze in thirty minutes?	115 [bad guys]
4	What is the number of inches in the perimeter of a right triangle with legs of length sixteen and thirty inches?	80 [inches]
5	Austin's scores for three math tests are eighty-nine, ninety-seven, and ninety. What score would he need on his fourth test to have an average of ninety-two?	92
6	An airplane cruises at an average rate of five hundred miles per hour. A bullet train travels at an average rate of two hundred miles per hour. How many minutes longer does a bullet train take to make the same seven-hundred-and-fifty-mile trip?	135 [minutes]
7	A square has side lengths of six inches. If the sides are all increased by thirty-three and one third percent, what is the number of square inches in the positive difference between the area of the new square and the area of the original square?	28 [in ²]
8	A group of kids are playing a certain card game where six cards are played every round. How many rounds will it take them to play two hundred and twenty-two cards?	37 [rounds]
9	Riley has three quarters, two dimes, and thirty-two pennies. What is the total number of cents in Riley's money?	127 [cents]
10	How many hours would it take Nat to drive two hundred and thirty-two miles if she drives at an average rate of twenty-nine miles per hour?	8 [hours]

"Math Is Cool" Championships — 2020-21

7/8th Grade — February 10, 2021

Sponsored by: Columbia Basin College

Key

COLLEGE BOWL ROUND #2

#	Problem	Answer
1	Together, a water bottle and a bag of chips cost two dollars and thirty-eight cents. In cents, how much does the bag of chips cost if it is ten cents cheaper than the water?	114 [cents]
2	What is the product of twenty-one and nineteen?	399
3	What is the positive difference between forty squared and forty-one squared?	81
4	An equilateral triangle has a perimeter of one hundred and forty-seven inches. What is the perimeter, in inches, of a square with the same side length as the triangle?	196 [inches]
5	What is the number of distinct prime factors in thirty thousand three hundred?	4 [factors]
6	How many ways can the letters A-B-C-D-E be put in order, not counting any arrangements that begin with E?	96 [ways]
7	The first two Fibonacci numbers are one and one. What is the sum of the seventh and ninth Fibonacci numbers?	47
8	What is the number of inches in the radius of a circle with a circumference of thirty-six pi inches?	18 [inches]
9	What is the next term in the sequence that begins two, six, fourteen, thirty, and so on?	62
10	Two cards are randomly drawn from a standard deck without replacement. As a reduced common fraction, the probability that the first card is a diamond and the second card is black is A/B , where A is a two-digit whole number and B is a three-digit whole number. What is the value of A plus B ?	[$A + B =$] 115

"Math Is Cool" Championships — 2020-21

7/8th Grade — February 10, 2021

Sponsored by: Columbia Basin College

Key

COLLEGE BOWL ROUND #3

#	Problem	Answer
1	What is the sum of thirteen squared and fifteen squared?	394
2	What is fifty percent of ten percent of four hundred and sixty?	23
3	Miriam makes seventy-five percent of her free throws. If she shoots forty free throws, how many shots will she miss?	10 [shots]
4	Find the product of the mean, median, and mode of the following set of data: two, four, one, three, four, six, and eight	64
5	How many cups are in one and a half gallons?	24 [cups]
6	What is the product of all the numbers from one to eight inclusive?	40,320
7	Jeff plays Tetris for twenty-five minutes on all twenty-nine days during the month of February in a leap year. The number of hours Jeff plays Tetris in February is the reduced common fraction A/B . What is the value of A plus B ?	[$A + B =$] 157
8	Thanos is trying to find six stones to complete his collection. If it takes him five and a half days on average to find each stone, how many total days will he need to find all six stones?	33 [days]
9	Rita thinks of a number in her head, then adds seventy to the number, then divides the outcome by eleven. If her final number is seven, what number did Rita start with?	7
10	What is the product of the prime numbers between ten and eighteen?	2,431